



# Your Partner In Lift Solutions.

Catálogo Técnico.



Catálogo  
**Técnico Raloe**



01	▶ <b>Desarrollo de Producto</b>		
	1.1 Symbio	—	03
	1.2 Symbio grandes cargas	—	09
	1.3 Optimus	—	11
	1.4 Genesis	—	17
	1.5 Hydronic	—	21
	1.6 Soluciones Regenerativas	—	23

02	▶ <b>Acabados</b>		
	2.1 Modelos de cabina	—	25
	2.2 Cabinas panorámicas	—	31
	2.3 Acabados de cabinas	—	35
	2.4 Puertas	—	42
	2.5 Botoneras y Displays	—	45
	2.6 Estructuras	—	49





## 1.1

Symbio es el ascensor eléctrico con o sin cuarto de máquinas capaz de adaptarse a cualquier necesidad de hueco, de foso o de huida.

Amplio abanico de cargas.

### ► Aplicaciones

**Edificio Residencial**  
**Centro Comercial**  
**Obra Nueva**  
**Hoteles**  
**Hospitales**  
**Oficinas**  
**Montacamillas**  
**Edificios de Gran Altura**  
**Alto tráfico**

## Ventajas

Tanto para obra nueva como para hueco existente con fosos y huidas reducidas (EN 81.21).

### **Versatilidad:**

No es necesario el cuarto de máquinas, proporcionando mayor libertad de diseño del edificio. A pesar de que es el ascensor para huecos de obra nueva por excelencia, es adaptable a infinidad de huecos. Huecos especiales.

### **Flexibilidad/Adaptabilidad:**

Customizado a cada cliente. Amplio rango de cargas, tamaños y velocidades. Robusto, resistente y fiable. Posibilidad de ubicar la maniobra tanto en el marco de la puerta (ancho 120mm) como en el rellano. Tensión de línea trifásica o monofásica.

### **Confort:**

Gracias a la configuración con chasis centrados y suspensión 2:1, se garantiza un nivel de confort máximo durante el desplazamiento con una mínima contaminación acústica.

### **Gran durabilidad:**

Mantenimiento reducido. El aparato tiene una larga vida y las reparaciones son prácticamente nulas.

### **Fácil instalación:**

Diseño maduro, plug and play. Bancada autoportante soportada sobre las propias guías.

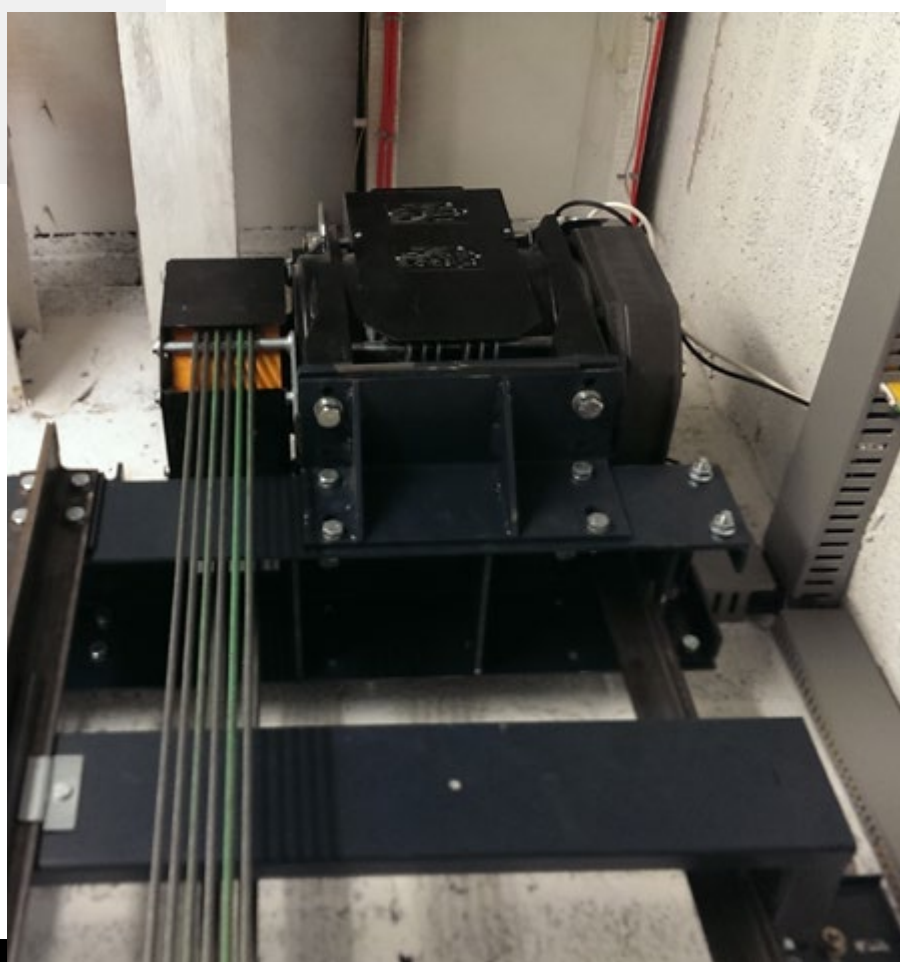

## Características Técnicas

<b>Carga Nominal (Kg)</b>	300 - 1.600
<b>Velocidad Nominal (m/s)</b>	0,5 - 3,0
<b>Cuarto de Máquinas</b>	CCM / SCM
<b>Recorrido (m)</b>	Hasta 100
<b>Suspensión</b>	2:1
<b>Diámetro del Cable (mm)</b>	6,5 - 8,0
<b>Sistema de Guiado</b>	Deslizaderas amortiguadas alto confort.

Q (kg)	Fosos mínimos (mm)		Huidas mínimas (mm) <sup>(1)</sup>	
	Foso mín.	Huida necesaria	Huida mín.	Foso necesario
<b>450</b>	340	3.370	2.985	615
<b>630</b>	340	3.370	2.985	660
<b>1.000<sup>(2)</sup></b>	340	3.370	3.000	660
<b>1.000<sup>(3)</sup></b>	345	3.415	3.090	680
<b>1.600</b>	450	3.540	3.330	705

<b>Embarques</b>	0° - 180°
<b>Tipo de Puerta</b>	Automática - Semiautomática
<b>Ascensor Panorámico</b>	Sí
<b>Ascensor Intemperie</b>	Sí

(1) Datos para instalaciones a 1 m/s. Huidas calculadas con una altura interior útil de cabina de 2.005 mm.

(2) Fosos y huidas mínimas para P+Q hasta 1.933 Kg.

(3) Fosos y huidas mínimas para P+Q hasta 2.750 Kg.

## Soluciones especiales

Posibilidad de configuraciones especiales para huecos irregulares.

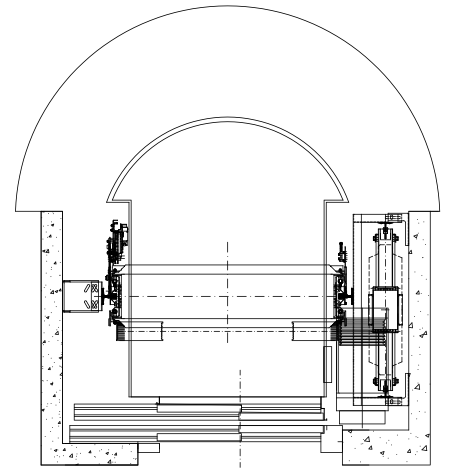

## Altas Velocidades V-

Hasta 3m/s

Para velocidades  $\geq$  a 1,6 m/s, rodaderas triples. Máximo confort.

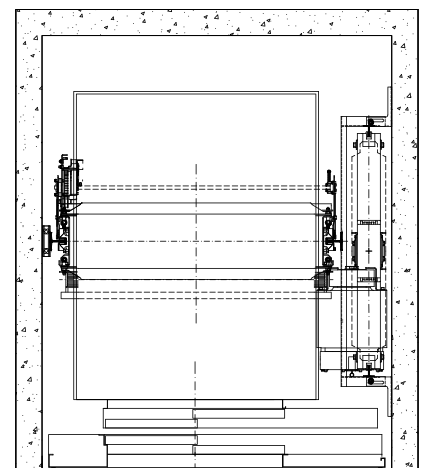
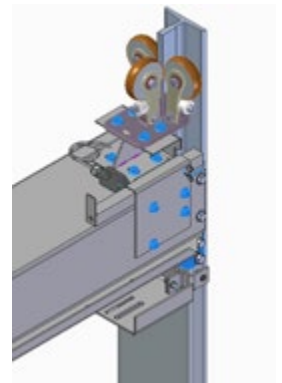

## Características Técnicas Symbio HR

**Carga Nominal (Kg)** 300 - 1.600

**Velocidad Nominal (m/s)** 0,5 - 1,0

**Cuarto de Máquinas** CCM / SCM

**Recorrido (m)** Hasta 50

**Suspensión** 2:1

**Diámetro del Cable (mm)** 6,5 - 8,0

**Sistema de Guiado** Deslizaderas amortiguadas alto confort.

Q (Kg)	Huidas Mínimas (mm) <sup>(2)</sup>	
	Huida necesaria	Foso mín.
<b>450</b>	2.430	615
<b>630</b>	2.430	660
<b>1.000<sup>(3)</sup></b>	2.430	660
<b>1.000<sup>(4)</sup></b>	2.430	680
<b>1.600</b>	2.760	705

**Embarques** 0° - 180°

**Tipo de Puerta** Automática - Semiautomática

**Ascensor Panorámico** Sí

**Ascensor Intemperie** Sí

## Soluciones a medida

Symbio HR  
Huida 2.430 mm.<sup>(1)</sup>

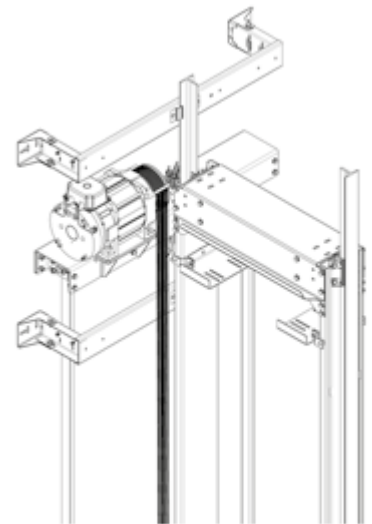

(1) Huida mínima alcanzable para cabinas EN81.70 Tipo 2 y ancho de hueco 1.600 mm.  
(2) Datos para instalaciones a 1 m/s. Huidas calculadas con una altura interior útil de 2.005 mm.

(3) Fosos y huidas mínimas para P+Q hasta 1.933 Kg.

(4) Fosos y huidas mínimas para P+Q hasta 2.750 Kg.



## Características Técnicas Symbio PF

<b>Carga Nominal (Kg)</b>	300 – 600 <sup>(1)</sup>
<b>Velocidad Nominal (m/s)</b>	0,5 – 1,0
<b>Cuarto de Máquinas</b>	CCM / SCM
<b>Recorrido (m)</b>	Hasta 50
<b>Suspensión</b>	2:1
<b>Diámetro del Cable (mm)</b>	6,5
<b>Sistema de Guiado</b>	Deslizaderas amortiguadas alto confort.

Symbio PF  
Fondo Huevo 720 mm.

Velocidad máxima: 1 m/s.  
Armario maniobra en rellano.

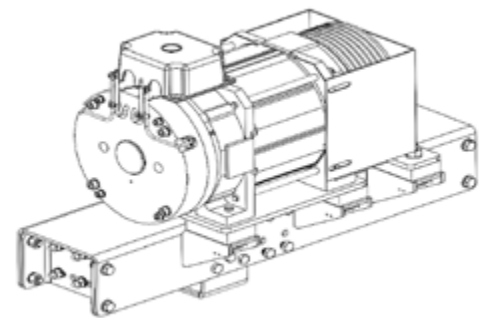

Q (Kg)	Fosos mínimos (mm)		Huidas Mínimas (mm) <sup>(2)</sup>	
	Foso mín.	Huida necesaria	Huida mín.	Foso necesario.
<b>450</b>	340	3.370	2.985	615
<b>630</b>	340	3.370	2.985	660

**Embarques** 0° – 180°

**Tipo de Puerta** Automática - Semiautomática

(1) Para el resto de cargas, consultad.

(2) Datos para instalaciones a 1 m/s. Huidas calculadas con una altura interior útil de cabina de 2.005 mm.

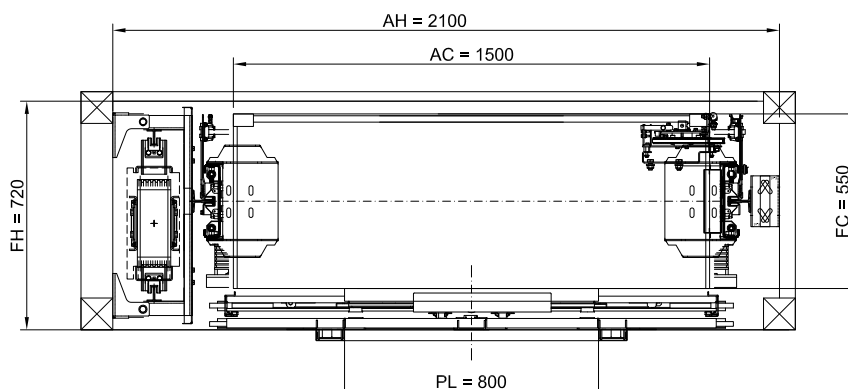



## Características Técnicas Symbio G

<b>Carga Nominal (Kg)</b>	1.800-3.000
<b>Velocidad Nominal (m/s)</b>	0,5 - 1,0
<b>Cuarto de Máquinas</b>	CCM / SCM
<b>Recorrido (m)</b>	Hasta 70
<b>Suspensión</b>	2:1
<b>Diámetro del Cable (mm)</b>	8 - 10
<b>Sistema de Guiado</b>	Deslizaderas alto confort. Para velocidades $\geq 1,6$ m/s, siempre rodaderas triples.
<b>Fosos mínimos (mm)</b>	780
<b>Huidas mínimas (mm)</b>	3.485
<b>Embarques</b>	0° - 180°
<b>Tipo de Puerta</b>	Automática
<b>Ascensor Panorámico</b>	Sí
<b>Ascensor Intemperie</b>	Sí

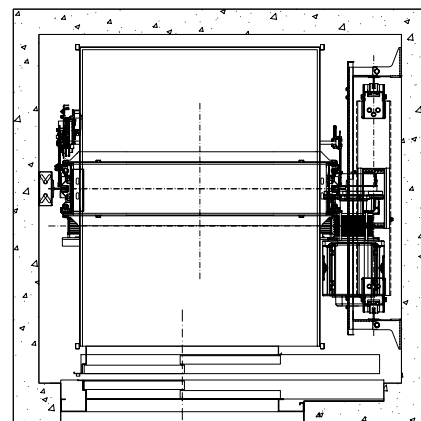



## 1.2

Ascensor Symbio sin cuarto de máquinas para grandes cargas con suspensión 4:1.

### ► Aplicaciones

**Centro Comercial**  
**Hoteles**  
**Hospitales**  
**Oficinas**  
**Grandes cargas**  
**Industria**

## Características Técnicas Symbio GC

Carga Nominal (Kg) 3.100 - 7.000

Velocidad Nominal (m/s) 0,5 - 1,0

Cuarto de Máquinas CCM / SCM

Recorrido (m) Hasta 70

Suspensión 4:1

Diámetro del Cable (mm) 10

Carga (Kg)	Altura int. cabina (mm)	Foso máximo (mm) Aproximado	Huida mínima (mm) Aproximado
7.000	3.000	2.000	5.500
5.000	2.500	1.600	4.500
4.000	2.500	1.600	4.500

Embarques 0° - 180°

Tipo de Puerta Automática

Ascensor Panorámico Sí

Ascensor Intemperie Sí

## Ventajas

### Confort:

Tracción 4:1 con poleas por debajo del chasis, proporcionando una excelente estabilidad y gran confort.

### Fácil instalación:

Bancada autoportante y viga de poleas preparada para adaptarse al hueco.

### Adaptabilidad:

Posibilidad de antiderivas para cargas puntuales elevadas.

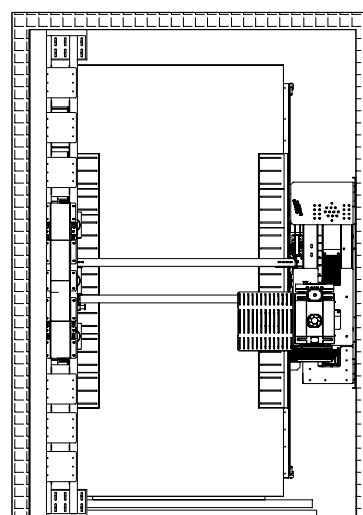
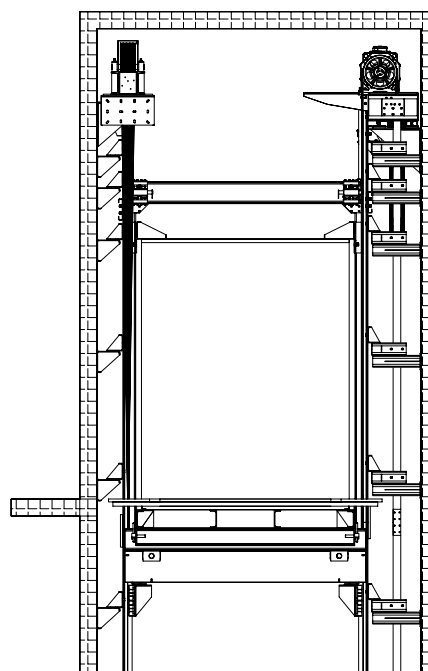



## 1.3

Optimus es el ascensor eléctrico con o sin cuarto de máquinas que más optimiza el hueco del mercado.

### ► Aplicaciones

**Residenciales**  
**Modernizaciones**  
**Huecos Existentes**  
**Rehabilitaciones**  
**Huecos mínimos**

## Ventajas

**Flexibilidad:**

Permite configuración de simple, doble y triple embarque. Ideal para soluciones a 90°.

**Monofásico:**

Funciona en cualquier enchufe monofásico 220V.

**Fácil instalación:**

Bancada de fácil montaje. Autoportante.

**Adaptabilidad:**

Posibilidad de diseño con norma EN 81.21 para foso y huida reducida. Customizado a cada cliente.

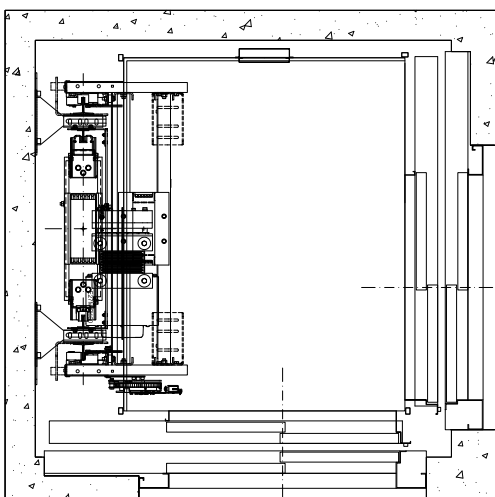
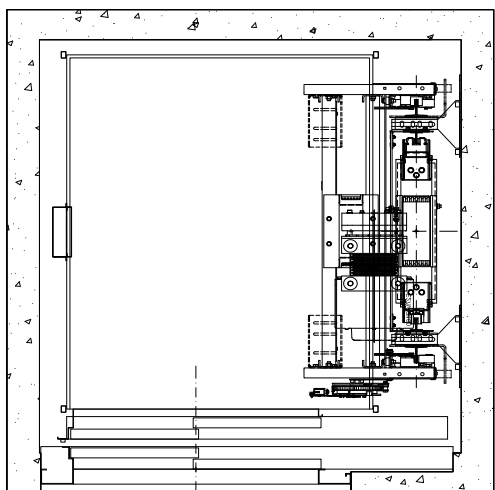

## Características Técnicas

**Carga Nominal (Kg)** 180 - 1.250

**Velocidad Nominal (m/s)** 0,5 - 1,0

**Cuarto de Máquinas** CCM / SCM

**Embarques** 0° - 90° - 180° - 270°

**Suspensión** 1:1 2:1

**Diámetro del Cable (mm)** 6,5 - 8,0

**Sistema de Guiado** Pivotantes o rodaderas en el lado de la caja de cuñas para garantizar funcionamiento.

Q (Kg)	Fosos mínimos		Huidas mínimas <sup>(1)</sup>	
	Foso mín.	Huida necesaria	Huida mín.	Foso necesario.
<b>450</b>	300	3.400	3.225	640
<b>630</b>	300	3.400	3.225	640
<b>1.250</b>	470	3.050	3.050	470

**Recorrido (m)** Hasta 50

**Tipo de Puerta** Automática - Semiautomática

**Cota técnica (mm)** 270

**Ascensor Panorámico** Sí

**Ascensor Intemperie** Sí

**Tensión Alimentación** Monofásica / Trifásica

(1) Datos para instalaciones a 1 m/s. Huidas calculadas con una altura interior útil de cabina de 2.005 mm

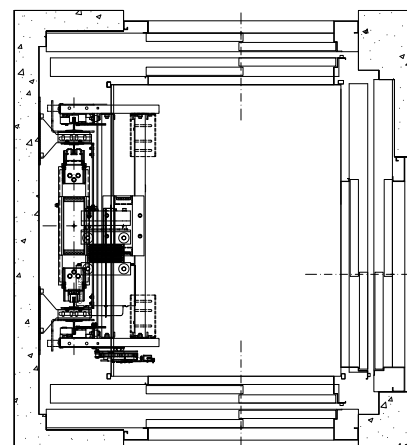

## Características Técnicas Optimus FHR

<b>Carga Nominal (Kg)</b>	180 - 630
<b>Velocidad Nominal (m/s)</b>	0,5 - 1,0
<b>Cuarto de Máquinas</b>	CCM / SCM
<b>Embarques</b>	0° - 90° - 180° - 270°
<b>Suspensión</b>	2:1
<b>Diámetro del Cable (mm)</b>	6,5
<b>Sistema de Guiado</b>	Pivotantes o rodaderas en el lado de la caja de cuñas para garantizar funcionamiento.
<b>Fosos mínimos (mm)</b>	300
<b>Huidas mínimas (mm)<sup>(1)</sup></b>	2.750
<b>Recorrido (m)</b>	Hasta 50
<b>Tipo de Puerta</b>	Automática - Semiautomática
<b>Cota técnica (mm)</b>	435
<b>Ascensor Panorámico</b>	Sí
<b>Ascensor Intemperie</b>	Sí
<b>Tensión Alimentación</b>	Monofásica / Trifásica

(1) Datos para instalaciones a 1 m/s. Huidas calculadas con una altura interior útil de cabina de 2.005 mm

## Soluciones a medida

### Cota Técnica 435 mm.

Q máx: 630 Kg (Qt máx: 1550 Kg)  
Foso mínimo: 300 mm.  
Huida mínima: 2400 mm.  
Cota técnica: 435 mm.

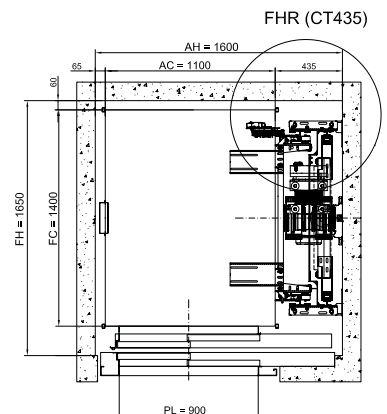

### FHR-3D

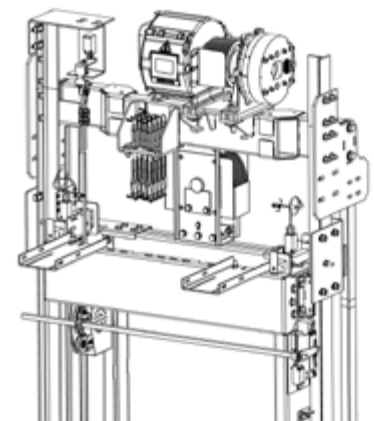

## Características Técnicas Optimus GP

<b>Carga Nominal (Kg)</b>	180 - 375
<b>Velocidad Nominal (m/s)</b>	0,5 - 1,0
<b>Cuarto de Máquinas</b>	CCM / SCM
<b>Embarques</b>	0° - 90° - 180° - 270°
<b>Suspensión</b>	2:1
<b>Diámetro del Cable (mm)</b>	6,5
<b>Sistema de Guiado</b>	Rozaderas
<b>Fosos mínimos (mm)</b>	350
<b>Huidas Mínimas (mm)<sup>(1)</sup></b>	Si HR 2.750 mm/ Si normal 3.200 mm
<b>Recorrido (m)</b>	Hasta 50
<b>Tipo de Puerta</b>	Automática - Semiautomática
<b>Cota técnica (mm)</b>	410
<b>Ascensor Panorámico</b>	Sí
<b>Ascensor Intemperie</b>	Sí
<b>Tensión Alimentación</b>	Monofásica / Trifásica

(1) Datos para instalaciones a 1 m/s. Huidas calculadas con una altura interior útil de cabina de 2.005 mm

Optimus GP  
Ancho hueco 650 mm.

Q máxima: 375 kg (Qt máx: 1165 kg.)  
Foso mínimo: 350 mm.  
Huida mínima: 3.200 mm.  
Cota técnica: 410 mm.  
Armario maniobra en rellano.

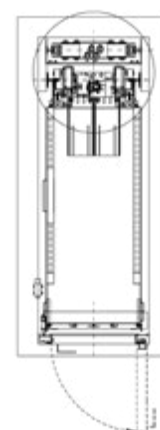
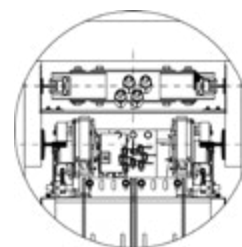
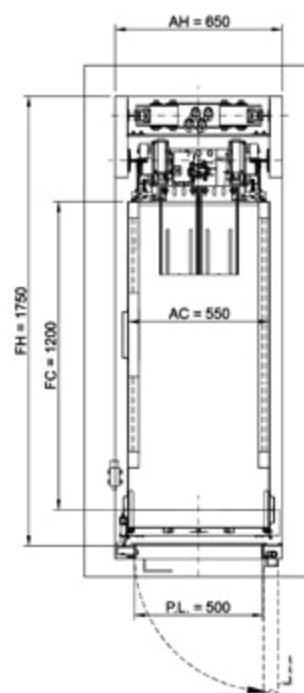



## Caract. Técnicas Optimus FHR cota reducida

<b>Carga Nominal (Kg)</b>	180 - 630
<b>Velocidad Nominal (m/s)</b>	0,5 - 1,0
<b>Cuarto de Máquinas</b>	CCM / SCM
<b>Embarques</b>	0° - 90° - 180° - 270°
<b>Suspensión</b>	2:1
<b>Diámetro del Cable (mm)</b>	6,5
<b>Sistema de Guiado</b>	Rozaderas
<b>Fosos mínimos (mm)</b>	350
<b>Huidas Mínimas (mm) <sup>(1)</sup></b>	2.460
<b>Recorrido (m)</b>	Hasta 50
<b>Tipo de Puerta</b>	Automática - Semiautomática
<b>Cota técnica (mm)</b>	350
<b>Ascensor Panorámico</b>	Sí
<b>Ascensor Intemperie</b>	Sí
<b>Tensión Alimentación</b>	Monofásica / Trifásica

Optimus 81.70  
Emb 90°

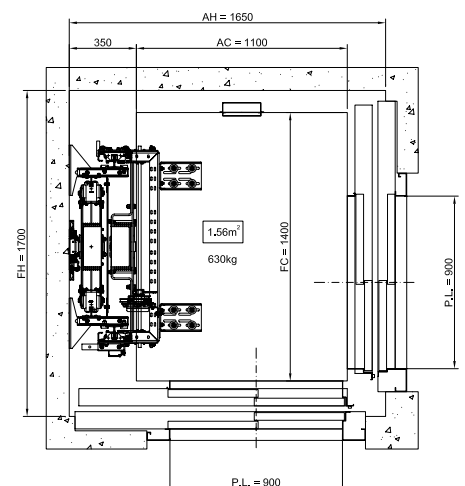

(1) Datos para instalaciones a 1 m/s. Huidas calculadas con una altura interior útil de cabina de 2.005 mm



## 1.4

Genesis es el ascensor eléctrico convencional con cuarto de máquinas, disponible con Reductor o con Gearless.

### ► Aplicaciones

**Rehabilitaciones**  
**Edificios de Gran Altura**  
**Alto Tráfico**  
**Modernizaciones**

## Características Técnicas Genesis

Carga Nominal (Kg) 300 - 5.000

Velocidad Nominal (m/s) 0,63 - 3,0

Cuarto de Máquinas CCM

Recorrido (m) Hasta 100

Suspensión 1:1 - 1:2 - 4:1

Diámetro del Cable (mm) 6,5 - 8 - 10 - 12

Sistema de Guiado Deslizadera >1,6 Rollers

Q (kg)	Fosos mínimos (mm)		Huidas mínimas <sup>(1)</sup> (mm)	
	Foso mín.	Huida mín.	Foso mín.	Huida mín.
450	360	3.170	685	3.040
600	360	3.170	715	3.135
1.000	730	3.315	730	3.315
1.350	730	3.315	730	3.315

Embarques 0° - 90° - 180° - 270°

Tipo de Puerta Automática-Semiautomática

Máquinas Fabricante Reductores - Gearless

Ascensor Panorámico Sí

Ascensor Intemperie Sí

(1) Datos para instalaciones a 1m/s. Huidas calculadas con una altura interior útil de cabina de 2.105 mm

## Soluciones a medida

## Ventajas

### Adaptabilidad:

Facilidad de adaptarse a los huecos existentes.

### Versatilidad:

Grandes cargas y largos recorridos.

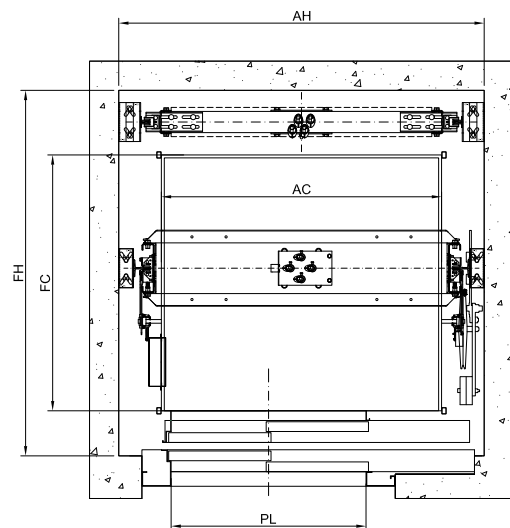

## Guías Esquinadas

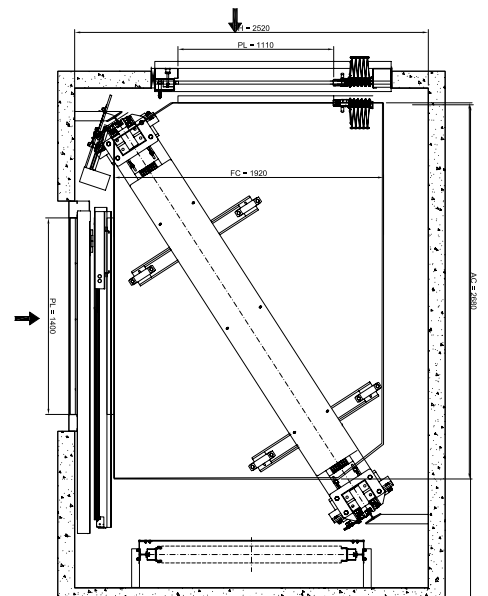



## 1.5

Hydronic es el ascensor hidráulico ideal para edificios existentes, capaz de adaptarse a cualquier tipo de hueco.

### ► Aplicaciones

**Residenciales**  
**Modernizaciones**  
**Huecos Existentes**  
**Rehabilitaciones**  
**Huecos mínimos**

## Ventajas

### **Versatilidad:**

Adaptamos cada ascensor a cada hueco diferente optimizando espacios.

### **Fosos y Huidas reducidos:**

En edificio existente, adaptamos nuestros ascensores en cumplimiento de la normativa para fosos y huidas reducidos (EN 81.21).

### **Confort:**

Excelente nivel de confort que se iguala al ascensor eléctrico utilizando válvulas electrónicas.

### **Adaptabilidad:**

Fácil regulación y mantenimiento.

### **Seguridad:**

Maniobra de emergencia automática siempre activa en bajada, incluso con fallo del motor.

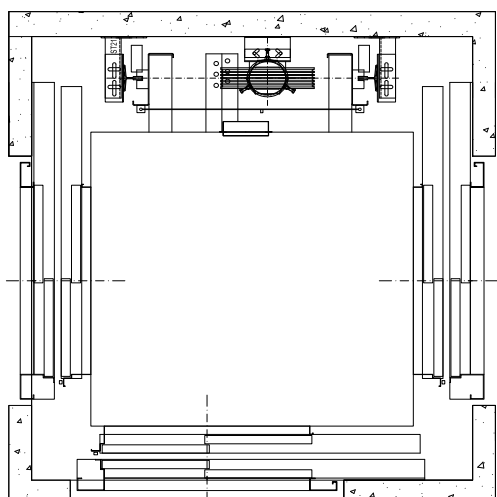
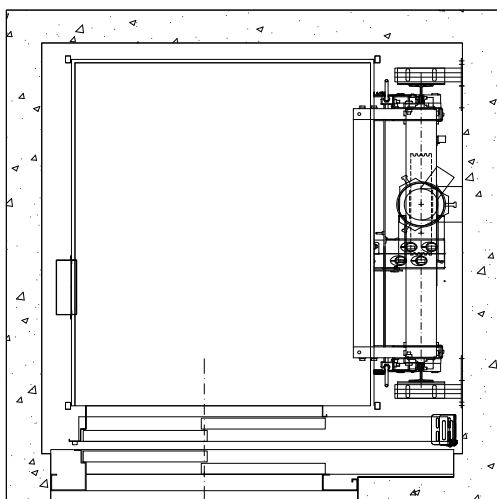

## Características Técnicas

**Carga Nominal (Kg)** 100 - 1.800

**Velocidad Nominal (m/s)** 0,2 - 0,63 Opción hasta 1

**Cuarto de Máquinas** CCM / Central en armario / Central foso

**Embarques** 0° - 90° - 180° - 270°

**Suspensión** 1:1 2:1

**Diámetro del Cable (mm)** 6,5 - 8 - 9 - 10 - 12

**Sistema de Guiado** Pivotantes o rodaderas en el lado de la caja de cuñas para garantizar funcionamiento.

Fosos y huidas mínimas (mm)		
Q (kg)	Foso mín.	Huida mínima
320	255	2.720
630	265	2.660
1.000	350	2.860
1.250	740	2.860
1.600	740	2.860

**Recorrido (m)** Hasta 25

**Tipo de Puerta** Automática - Semiautomática

**Equipos hidráulicos** GMV - MORIS - BUCHER

**Ascensor Panorámico** Sí

**Ascensor Intemperie** Sí

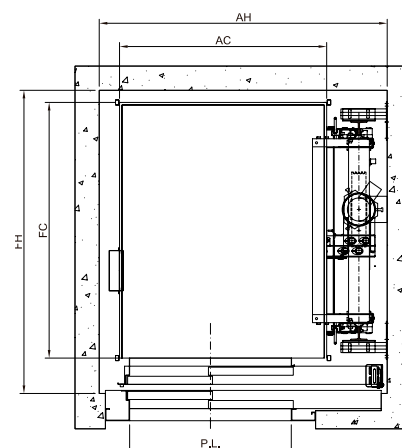

Panorámicos

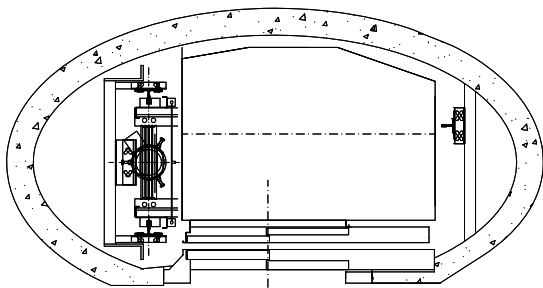

Huecos irregulares

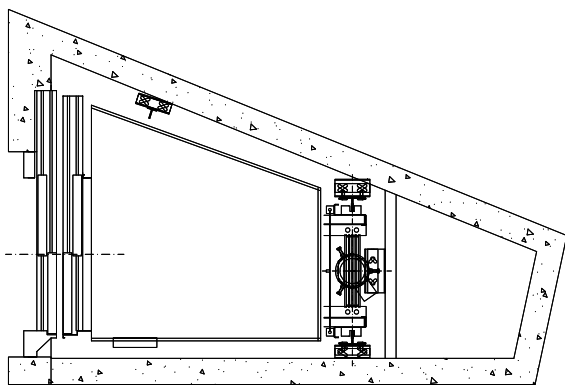

Pistones enterrados

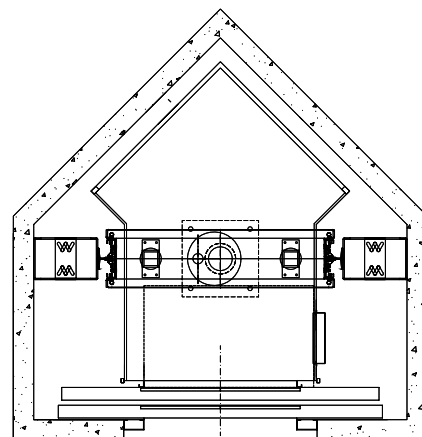
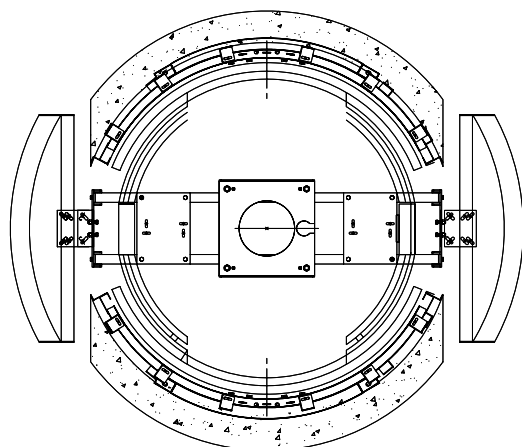

## ERS 2G – Energy Recovery System

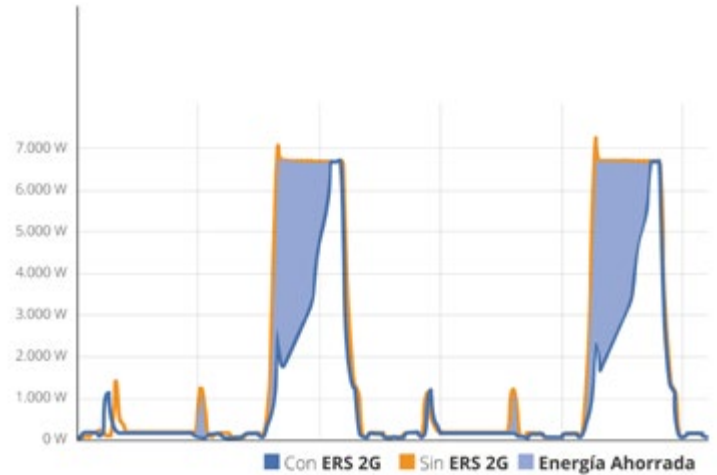

- ▶ Revoluciona el consumo del ascensor. Solución regenerativa con almacenamiento de energía. Recupera la energía generada por el ascensor y la devuelve al mismo ascensor reduciendo el consumo de tracción en hasta un 70%. Enchufar y listo.

## P2S – plug to single-phase

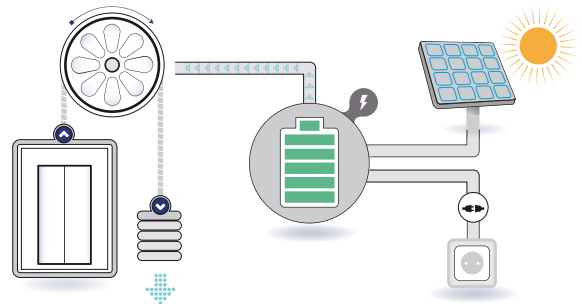

- ▶ Alimenta un ascensor trifásico desde cualquier acometida monofásica con 500W máximos de consumo. Permite el uso del ascensor en caso de corte de luz y permite transformar el ascensor en uno solar con solo 2 paneles.





Your Partner  
**In Lift Solutions.**





## 2.1 Modelos de cabina



101

**Paños**

Acero Inox. Checks



**Unión**

Lama sin separación

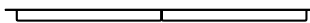

**Suelo**

Granito Natural Warwick

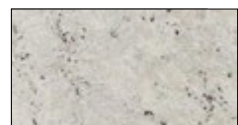

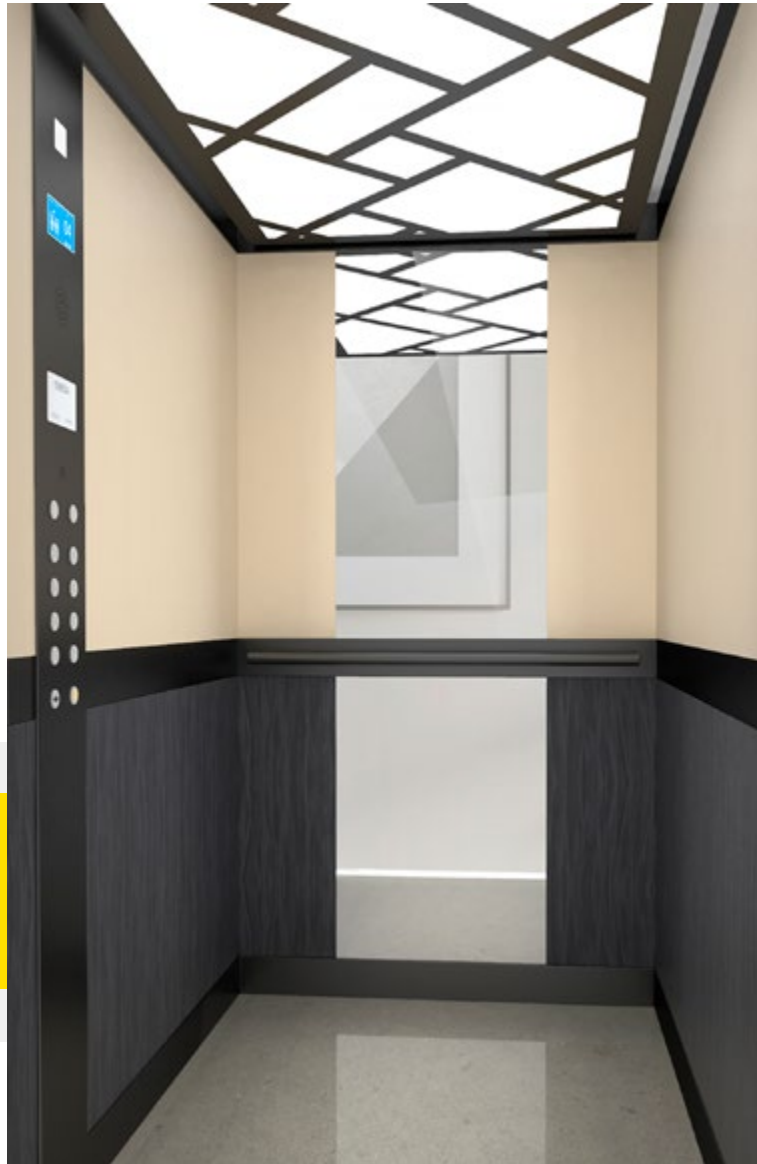

# L03

## Paños

F6307 Burnt Strand



F2833 Arena Pétrea

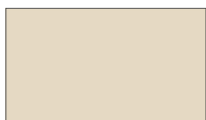

Laminado

## Unión

Paño liso

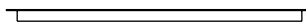

## Suelo

Piedra artificial Royal Reef



\* M03 también disponible en Melamina



## 2.1

## Modelos de cabina



### L04

#### Paños

F7327 Gris Popular



F8830 Elemental Concrete



Laminado

#### Unión

Paño liso



#### Iluminación paño

Pareja tiras LED  
verticales

\* M04 también disponible en Melamina



# S01

**Paños**

Skinplate Acero Inox



**Unión**

Lama sin separación



**Suelo**

Antideslizante negro





## 2.1 Modelos de cabina



### CH01

#### Paños

Marfil Claro RAL 1015



Chapa pintada

#### Unión

Lama sin separación

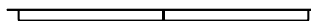

#### Suelo

Rosa Porriño





# Quartz

**Paños**

Rojo Terracota RAL 8815

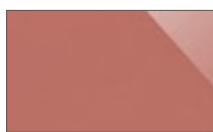

Vidrio lacado

**Unión**

Paño liso



**Suelo**

Negro Inteso





## Matrix

Cabinas rectangulares con diferentes variaciones en la disposición del cristal.

Modelos M100, M200, M300: Unión entre cristales enmarcado con perfiles.

Modelos M100d, M200d, M300d: Unión entre cristales sin perfiles.

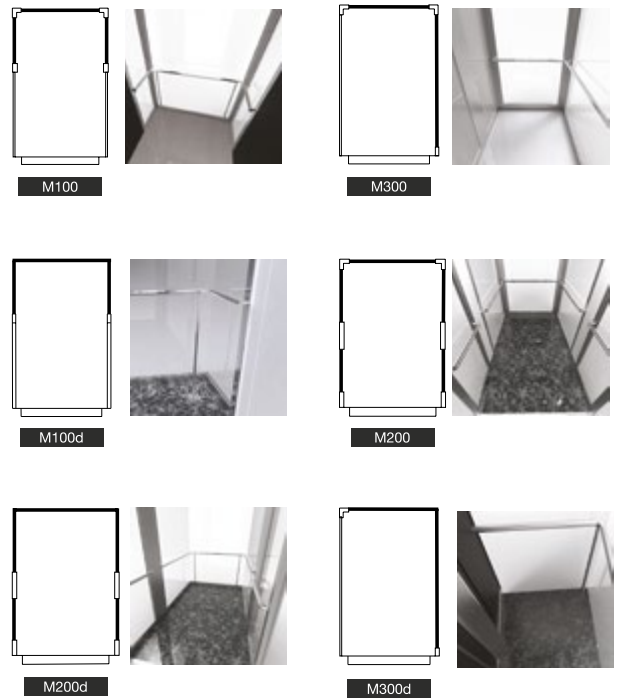

Disponemos de multitud de formas para las cabinas panorámicas con uno o más paños de cristal.





### Vector

Frontal de cabina poligonal o curvo, con o sin uniones entre cristales.

Modelos V100, V300: Unión entre cristales enmarcado con perfiles.

Modelos V100d, M300d: Unión entre cristales sin perfiles.

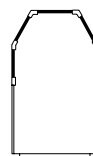

V100

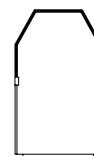

V100d

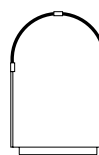

V300

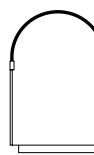

V300d



Consultar compatibilidad modelo/carga.



### Century

Cabinas acristaladas completamente circulares

Modelos C100: Unión entre cristales enmarcado con perfiles.

Modelos C200: Unión entre cristales sin perfiles.

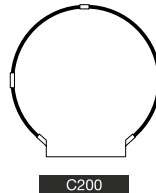
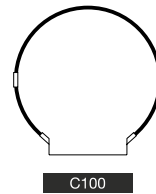



## 2.3 Acabados de cabina

### Paños

#### Skinplates



Blanco

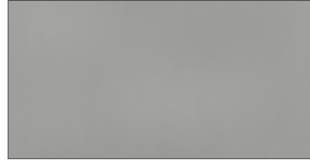

Simil Inox.



Gris



Acero Inox.

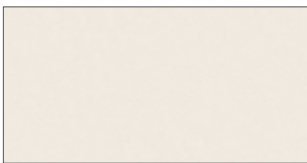

Crema

#### Chapa pintada



Blanco RAL 9016



Beige RAL 1019



Negro RAL 9005

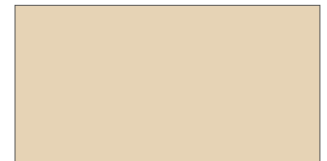

Marfil Claro RAL 1015



Gris metalizado RAL 9006

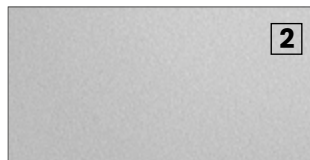

Gris claro perlado RAL 9022

2

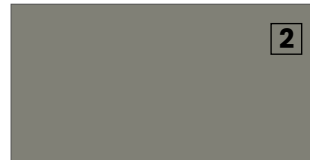

Gris Hormigón RAL 7023

2



Violeta Pastel RAL 4009

2

2 Tarifa Tipo 2

\*Cualquier otro RAL disponible bajo pedido

#### Aceros inoxidables



Satinado



Checks

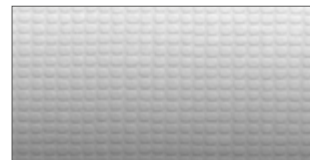

Canvas

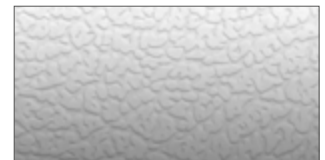

Cuero

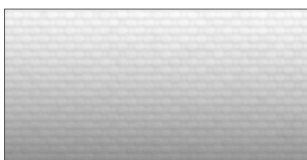

Linen



Pulido

Disponible cualquier otro acabado de:





## Paños

### Vidrio lacado

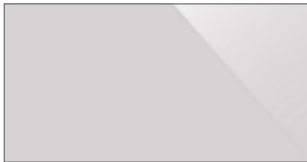

Gris metal RAL 9006



Marrón Claro RAL 1236

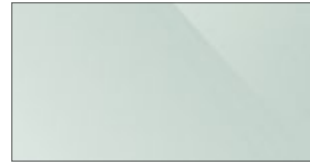

Verde RAL 8615



Aluminio RAL 9007

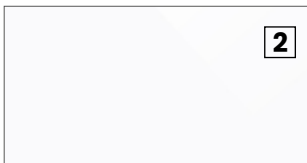

Blanco puro RAL 9003



Negro Estelar RAL 0337

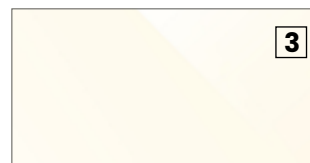

B. Perla RAL 1013 (mate o brillo)



Bronce

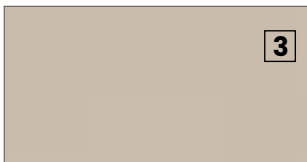

Marrón Claro RAL 1236 (Mate)



Rojo Terracota RAL 8815



Verde Pistacho RAL 1164

**2** Tarifa Tipo 2

**3** Tarifa Tipo 3

### Vidrio lacado bajo pedido



RAL 1586



RAL 8017

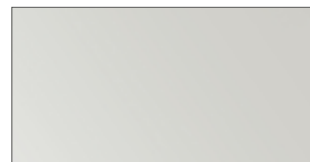

PLATA



RAL 5002



RAL 2001



RAL 9005

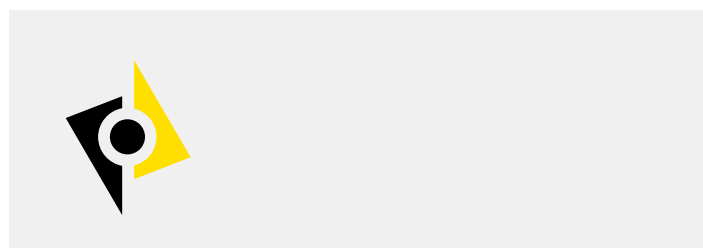



## 2.3 Acabados de cabina

### Laminados

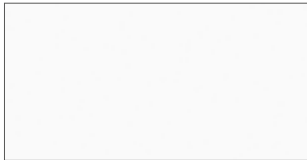

F2274 Blanco Francia



F1139 Cerezo



F7884 Azul China



F7837 Grafito

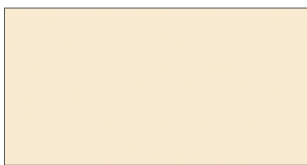

F2273 Seringa



F1062 Roble

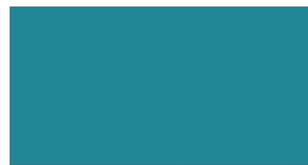

F2478 Turquesa

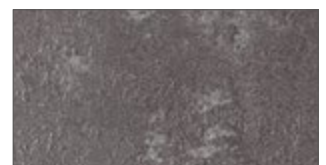

F8833 Elemental Graphite

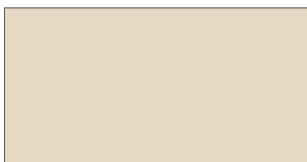

F2833 Arena pétrea



F5873 SET Ventura Oak



F1997 Oceano



F8832 Elemental Corten



F8841 White Ash

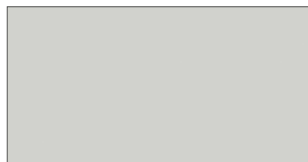

F7927 Gris Popular



F8849 Natural Teak

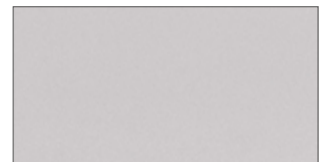

F0193 Xenon



F0190 Haya finlandesa

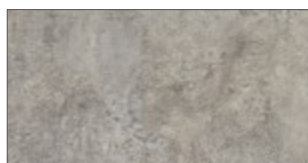

F8830 Elemental Concrete



F8848 Blackened Legno

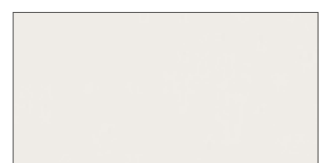

F7923 Surf



F3091 Blanco Polar Brillo



F6307 Burnt Strand

**3** Tarifa Tipo 3

\* Resto de formicas disponibles en  
<https://www.formica.com/es-es>

Los colores mostrados pueden variar respecto a los reales, en función de la configuración del monitor o de las condiciones de impresión.



## Paños

### Melamina

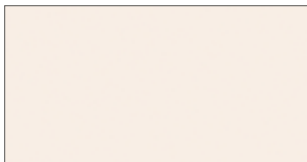

Crema



Pino Cervino

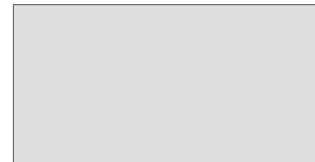

Gris



Haya

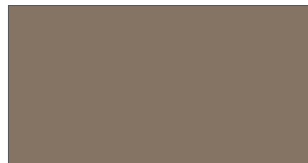

Chocolate



Cerezo

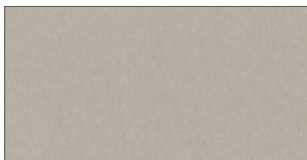

Lino Habana Textil



Roble Renovales

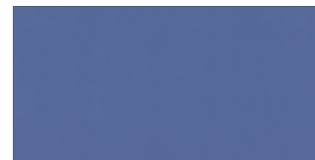

Azul



No cumplen norma EN 81.20



## 2.3 Acabados de cabina

### Suelos

#### Goma antideslizante 4,5 kg / m<sup>2</sup>

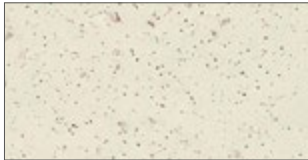

Beige



Roble



Azul acero



Arena

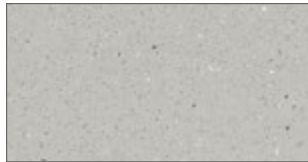

Gris

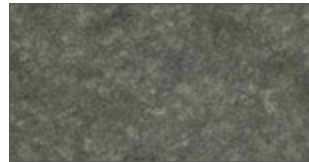

Gris cemento



Negro

#### Piedra artificial 49 kg / m<sup>2</sup>



Gris Expo

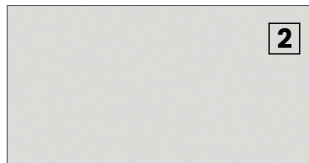

Blanco Norte



Ethereal Glow

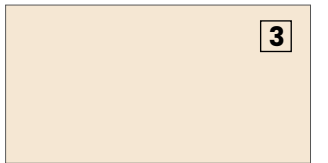

Rougui

**2** Tarifa Tipo 2

**3** Tarifa Tipo 3

**Granito natural 56 kg / m<sup>2</sup>**



Gris Perla

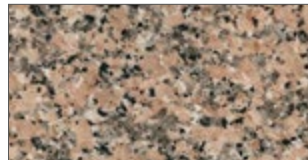

Rosa Porriño



Blanco Cristal



Blanco Trevi



Gris Quintana

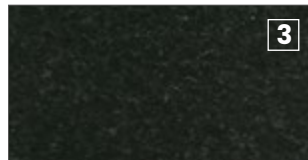

Negro Intenso

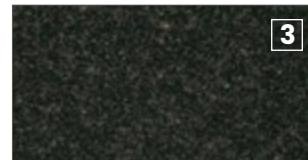

Negro Sudáfrica



Azul Labrador oscuro



Guyana

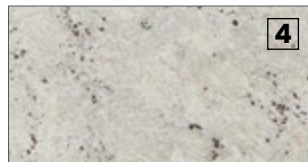

Warwick Rubi

**2** Tarifa Tipo 2

**3** Tarifa Tipo 3

**4** Tarifa Tipo 4

**Suelos metálicos**



Aluminio Damero 6 Kg/m<sup>2</sup>



Acero Inox. 12 Kg/m<sup>2</sup>



Chapa lagrimada 36 Kg/m<sup>2</sup>





## 2.3 Acabados de cabina

### Techos

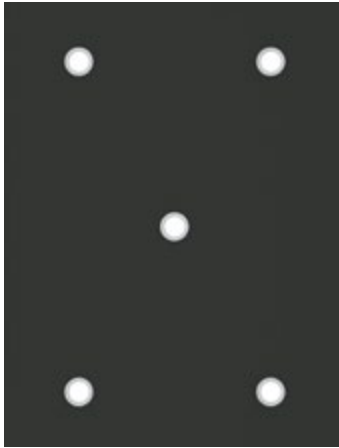

LED spots

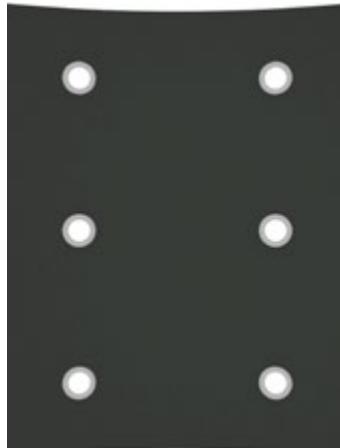

LED spots Curvo

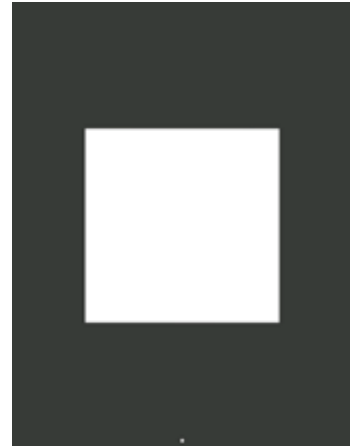

Panel LED



Mondrian

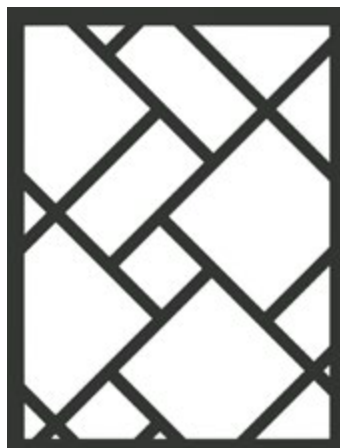

Arte

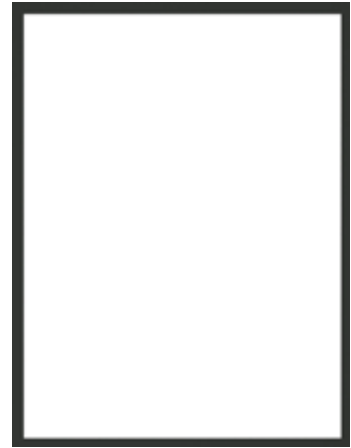

Marco

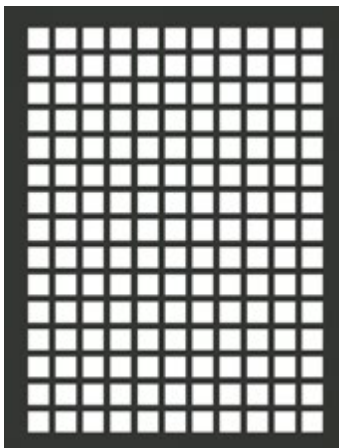

Mosaic



Cristal matizado

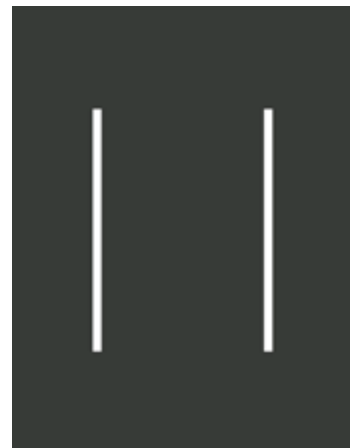

Barras LED

► Todos los techos se pueden seleccionar en color blanco, negro y acero inoxidable.

## Iluminación indirecta

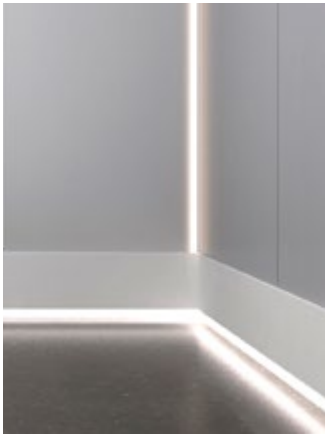

Iluminación en zócalo



Iluminación en paños



Iluminación en botonera

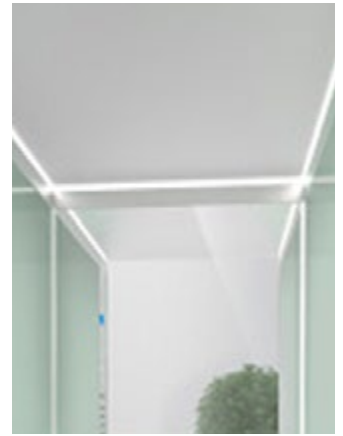

Iluminación en techo

## Espejos



Espejo 1/2



Espejo Lama

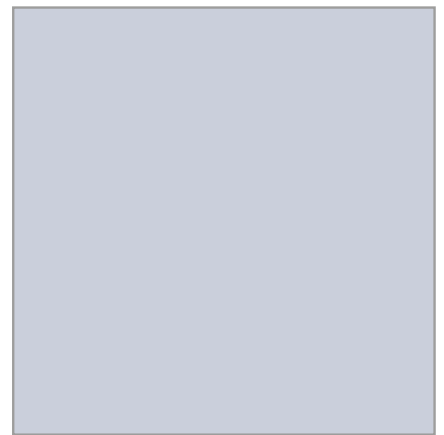

Espejo Entero

## Pasamanos NORMA EN 81-20

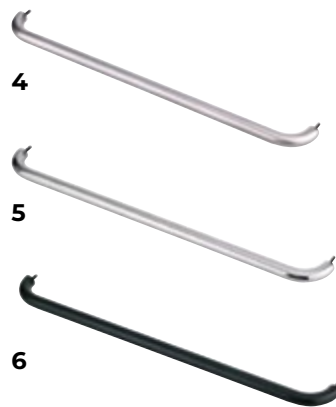
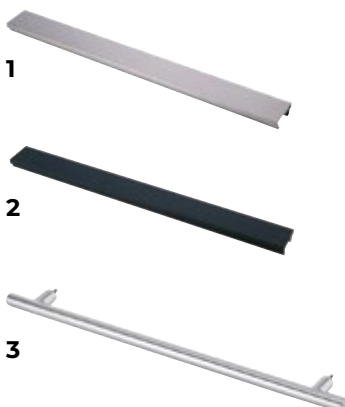

1. Rectangular inox.
2. Rectangular skinplate.
3. Tubular recto inox pulido.
4. Tubular curvo inox satinado.
5. Tubular curvo inox pulido.
6. Tubular curvo pintado en negro.

**Puertas automáticas**



Imprimación Acero Inox.



Gran mirilla



Bus cristal + aluminio



Cristal total Inox

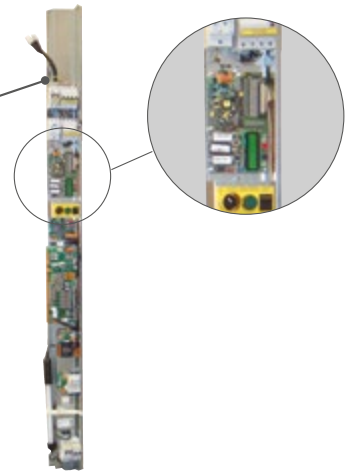

Cuadro de maniobra en marco puerta.

► Disponible en Carlos Silva, Elec Megom, Sprinte y NEW LIFT.



## Puertas semiautomáticas



Mirilla



Gran mirilla

**Acabados puertas**

► **Epoxi Gofrado**

ESTÁNDAR



RAL 7032

OTROS



RAL 9016

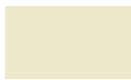

RAL 1015



RAL 9006



RAL 7004



RAL 1018



RAL 1019



RAL 6021



RAL 1034



RAL 3020



RAL 5012



RAL 8023



RAL 7010



RAL 7012



RAL 3004



RAL 6005



RAL 5011



RAL 9005

► **Acero inoxidable liso**

ESTÁNDAR



AISI 441 2B/BA



AISI 304 2B



AISI 316 2B



AISI 441 2B



AISI 304 2B



AISI 304 2B



AISI 316 2B



AISI 316 4N

DECORATIVO



AISI 304 BA



AISI 304 BA



AISI 316 BA



AISI 304 BA



AISI 304 BA



AISI 304 BA



AISI 304 BA

► **Acero inoxidable con relieve**



AISI 441 BA<sup>(1)</sup>



AISI 304 BA



AISI 304 BA



AISI 316 BA<sup>(1)</sup>



AISI 441 BA<sup>(1)</sup>



AISI 304 BA



AISI 304 BA



AISI 304 BA



AISI 441 BA<sup>(1)</sup>



AISI 304 BA



AISI 304 BA



AISI 316 BA<sup>(1)</sup>

Disponible cualquier otro acabado de:



## Botoneras cabina



### Tipo pasamanos (EN81.70)



- 1 Botonera columna estándar
- 2 Botonera de columna con iluminación
- 3 De superficie 920x220mm aluminio anodizado
- 4 Botonera de cristal

## Botoneras rellano



De superficie en aluminio



De superficie en aluminio



Grabado sobre acero



Con placa transparente



De superficie en INOX



Con Display

## Pulsadores



Bas 120



Bas 120 Black



RT42



US91-EN



US95-EN



US90 Jumbo



US95 Jumbo



B3 (Arkel)



B3 Black (Arkel)



V2-P (Arkel)

## Indicadores



DE SUPERFICIE

Displays

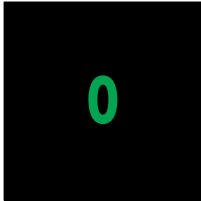

TFT 2,8"  
CARLOS SILVA



LCD10555  
AR KEL



EM2LCD  
MEGOM



LCDA  
AR KEL



TFT 5,6"  
CARLOS SILVA



MK\_800  
MEGOM



LIFTMEDIA  
AR KEL



7"  
CARLOS SILVA

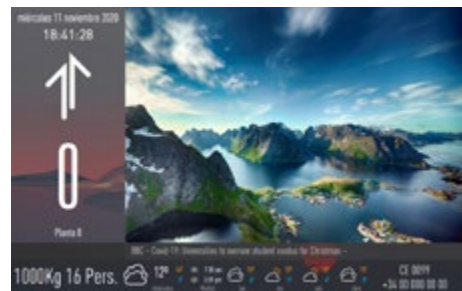

10"  
CARLOS SILVA





Your Partner  
**In Lift Solutions.**



## 2.6 Estructuras

Las estructuras para ascensor y homelift, nos aportan normalización y flexibilidad, suprimiendo las barreras arquitectónicas y aportando soluciones de accesibilidad total.

### ESTRUCTURAS

#### ► Colores



RAL 9002



RAL 3004



RAL 1015



RAL 6005



RAL 7032



RAL 5003



RAL 7001



RAL 9005



RAL 8003



OXIRON

## Ventajas

Los tiempos de obra y montaje se reducen en más de un 60% sobre una instalación con sistema constructivo tradicional, siendo un producto limpio, rápido y silencioso.

Absolutamente respetuoso con el medio ambiente, tanto en su proceso de montaje como en su desarrollo industrial.

Su facilidad de montaje, lo convierte en un producto altamente sencillo de trabajar, consiguiendo cumplir las más estrictas normas de seguridad.



## Características

Solución técnica polivalente para cada edificio, adaptándole de forma eficaz a las diferentes tipologías y necesidades constructivas. Las series TC, están diseñadas para integrarse en total armonía en el edificio existente y su entorno.

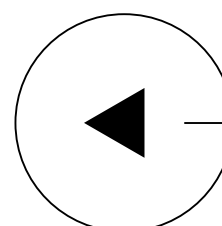



## Opciones **y** accesorios



Techo (chapa o cristal)



Tejadillo en puerta (chapa o cristal)



Pasamanos



Ventilación



# Tipos de cerramientos

---



Cristal butiral transparente

---

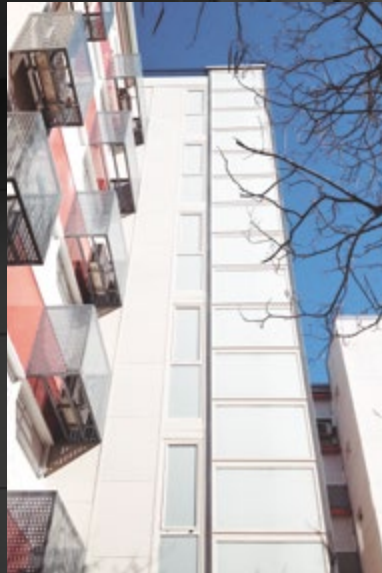

Cristal butiral matizado

---

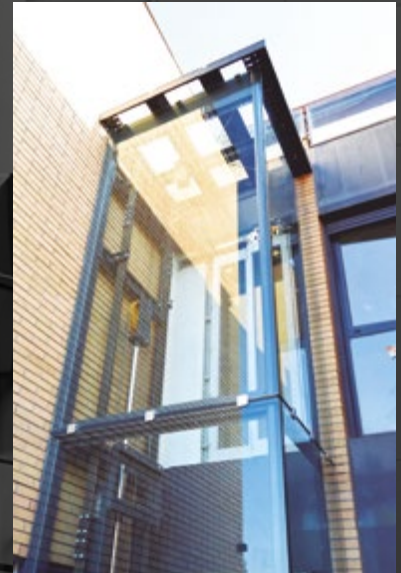

Cristal total

---



Chapa ciega

---



Chapa perforada

---



RALOE



## Oficinas y delegaciones

### CENTRAL / DELEGACIÓN VALENCIA

C/ Coeters, 27  
46980 Paterna  
+34 961 345 350  
comercial@raloe.com

### RALOE DEUTSCHLAND GmbH

Carl-Zeiss-Ring 14  
85737 Ismaning  
+49 (0) 89 306 44 765-0

### DELEGACIÓN MADRID

C/ Arboleda 18, Nave L  
28031 Madrid  
+34 913 013 720

### RALOE UK LTD

Office F08, The Nucleus  
Brunel Way, Dartford  
Kent DA1 5GA  
+44 (0) 759464 9122

### DELEGACIÓN BARCELONA

C/ Montserrat Roig, 56  
08908 L'Hospitalet  
+34 932 643 910

### DELEGACIÓN FRANCIA

Rue Alessandro Volta- 1er étage  
Zone Industrielle de Marcerolles  
26500 BOURG LES VALENCE  
+33 615 587 392

### RALOE EXPORT

+34 961 345 379  
export@raloe.com

WWW.RALOE.COM



